

Nombre de valeurs dépassant les normes

DBO5	0
Ptot	5
MES	3

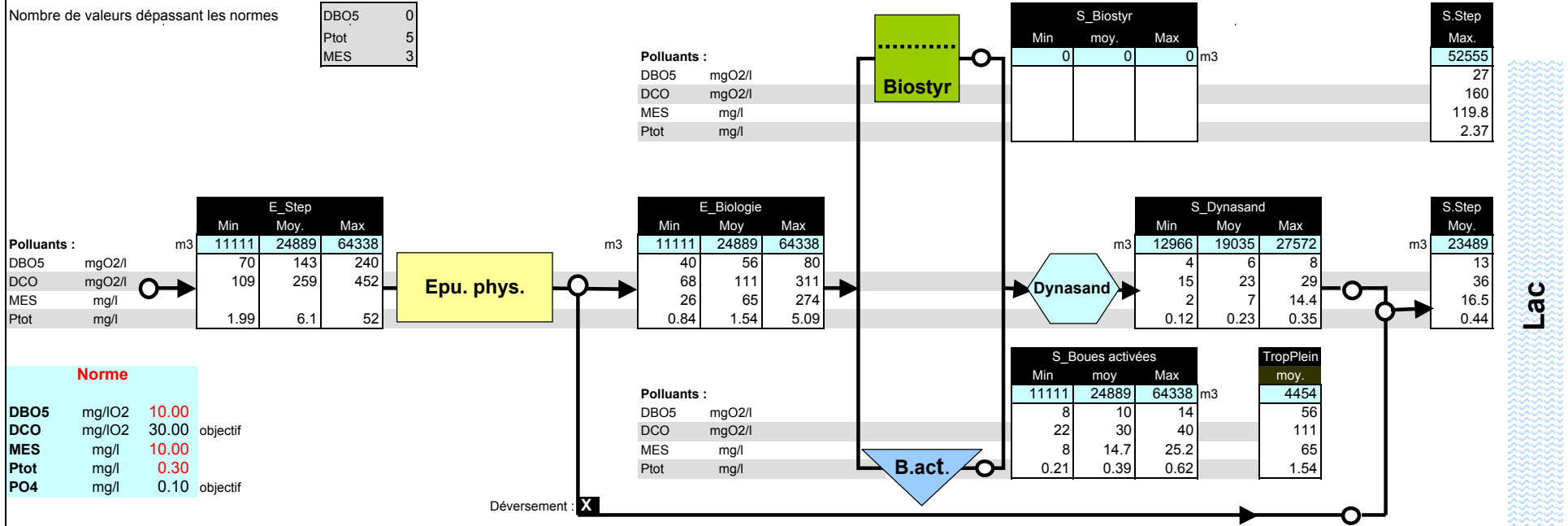

Abattement, moyennes journalières

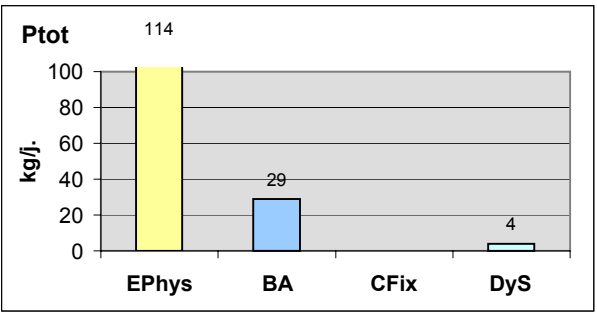
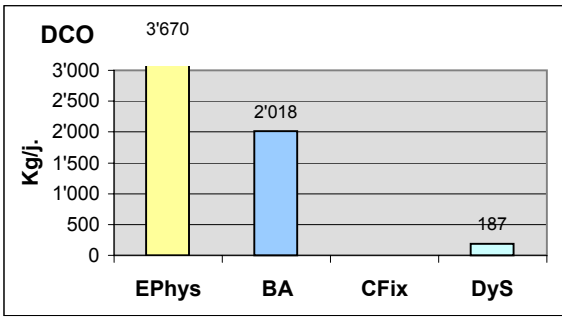
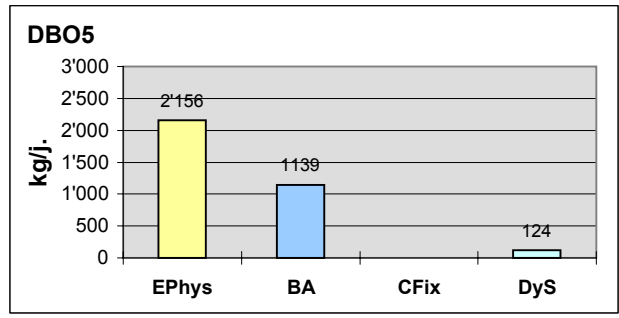

Rendements globaux : 96 % 91.2 % 96.2 %